

SERIES
B

SUBMERSIBLE
SEWAGE PUMPS

CHANNEL IMPELLER

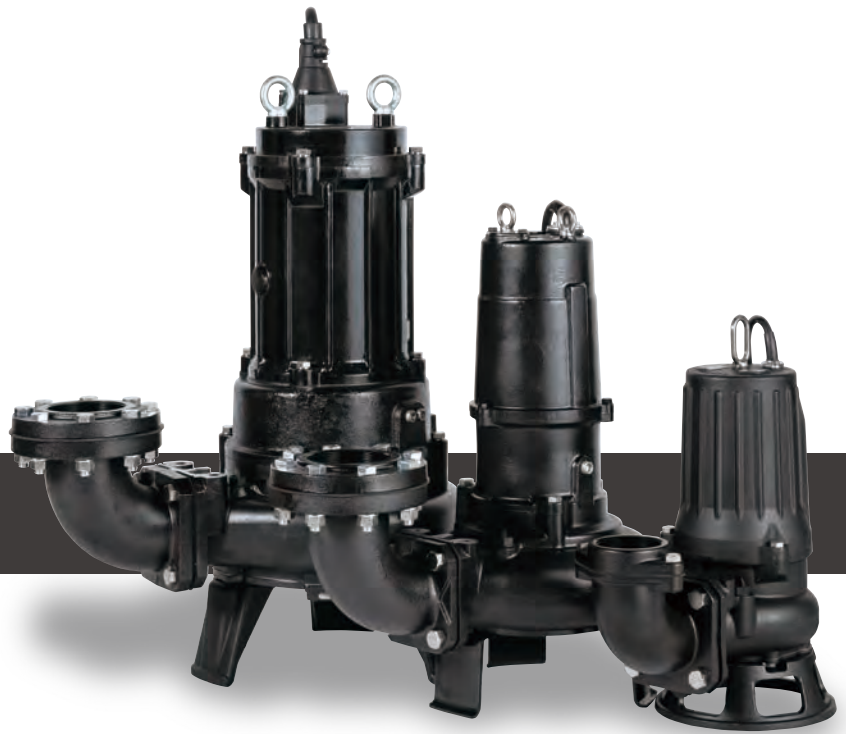

Submersible Sewage Pumps with Channel Impeller

Tsurumi B-series pumps are basic heavy-duty, submersible sewage and wastewater pumps providing excellent solids matter passing capability with reliable operation. The B-series pumps have accumulated various track record and know-how in a wide range of industrial and water treatment applications for many years. Using a channel impeller, they are designed to minimize trouble due to clogged solids and fibrous matter in pumped fluids.

The B-series offers a wide lineup of discharge bores ranging from 50 - 300 mm and motor outputs of 0.4 - 75 kW, and comes in a variety of models including high head type and single-phase BP models that can handle high volume pumping demand. Particularly, the high head type pumps can satisfy the needs of the building equipment market that is oriented to saving energy and conserving water, and fit other high head market applications. Moreover, the pumps can be used with Tsurumi's guide rail fitting device that facilitates installation and maintenance (except for BP models).

Tsurumi pumps come packed with a number of original technologies we have developed and honed over years of research, including an anti-wicking cable, motor protector, dual inside mechanical seals with silicon carbide faces and Oil Lifter. Highly reliable and durable, Tsurumi pumps are designed and built for sound quality and prolonged continuous operation.

The B-series pumps can help you keep your systems – whether for wastewater drainage, water treatment, flood control, irrigation and recreation facilities – running stably and greatly reduce your maintenance costs.

Additionally, the pumps can be specially configured with discharge bores of 400 mm and greater, or as an option, adapted for dry pit applications where they can be installed indoors and outside a tank, as well as for seawater or high temperature liquids, paving the way for their use at shipyards and power plants for water intake and discharge.



Selection Table

Motor Output (kW)	0.4	0.75	1.5	2.2	3.7	5.5	7.5	11	15	18.5	22	37	75
2" 50mm	★	★											
3" 80mm	☆	☆						●	●	●	●		
4" 100mm								●	●	●	●		
6" 150mm													
8" 200mm													
10" 250mm													
12" 300mm													

★: Single/Three-phase model can be selected in the same motor output.

☆: Single-phase model only.

●: High head type model only.

Model Number Designation

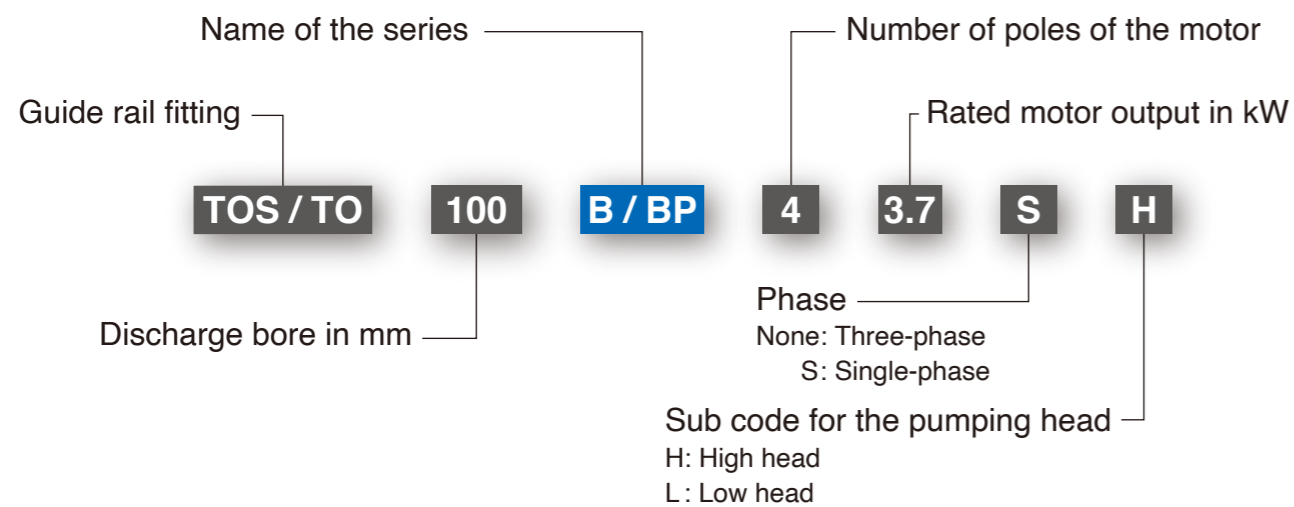

Guide Rail Fitting System

The guide rail fitting system connects the pump to and from the piping easily just by lowering and hoisting the pump, allowing easy maintenance and inspection without the need to enter the sump.

The TOS/TO is the guide rail fitting system made of cast iron and is compatible with cast iron pumps.

Accessories

- Duckfoot Bend
- Guide Support
- Guide Hook
- Lifting Chain 5m
- JIS 10kg/cm² Flange (TOS set only, excluding TOS200B422)



Guide Rail Fitting Operation

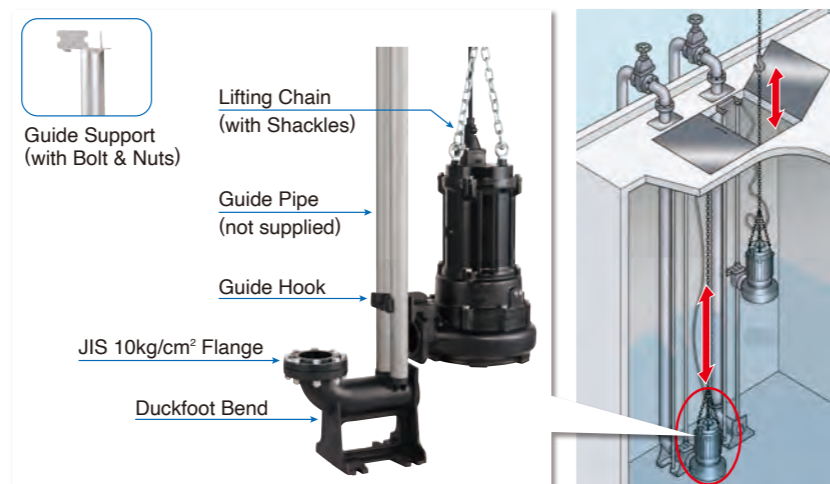

Float Switches

Tsurumi offers different types of float switches (liquid level sensors). A micro-switch is incorporated in all types. For details, refer to the float switches catalog [ID105].

Model MT-1 is an economy-type float switch. A teardrop body design with an integrated counterweight, MT-1 float switch is an ideal water level sensor for highly dense scum-filled wastewater. Moreover, equipped with the SPDT switch, it can be used as a water level sensor for filling as well as emptying operations.



Model MC-2 is a heavy-duty type float switch with a shock absorber. Having equipped with a high grade micro switch, the MC-2 assures trouble-free operation in the liquid containing much suspended solids and floating scum. Either of the two contacts, normally-open or normally-close, can be selected as required.



Options

Seawater-Resistant Version

In seawater, a material's resistance to corrosion can be seen clearly. When metals with different potentials are brought into contact in seawater, only the metal of lower potential corrodes. As the difference in potential increases, the metal of lower potential corrodes faster. As an option, Tsurumi can supply pumps with parts made of higher electric potential metal as the sacrificial anode.



High Temperature Liquids Version

Tsurumi's submersible pumps are applicable to high temperature liquids of up to 80°C. Pumps of the standard specification can discharge liquids of up to 40°C. However, there are many fields that need to discharge higher temperature liquids, e.g., discharging industrial water from a power plant or ironworks, or discharging hot spring water from a mine in a volcanic zone.



Special Material Version

Tsurumi can also provide you with pumps with essential components such as the impeller, pump casing and the suction cover made of non-standard materials. Select from stainless steel, high-chromium cast iron and bronze to suit your specific requirements.



Dry Pit Version

The dry pit pumps can be installed indoors and outside of tanks, and still deliver the performance of conventional submersible pumps. Daily inspection and maintenance are easy, because the pump body is installed outside of tanks. These pumps have been developed with Tsurumi-original specifications, aiming for stable operation and reduction in maintenance labor.



Model
150B437

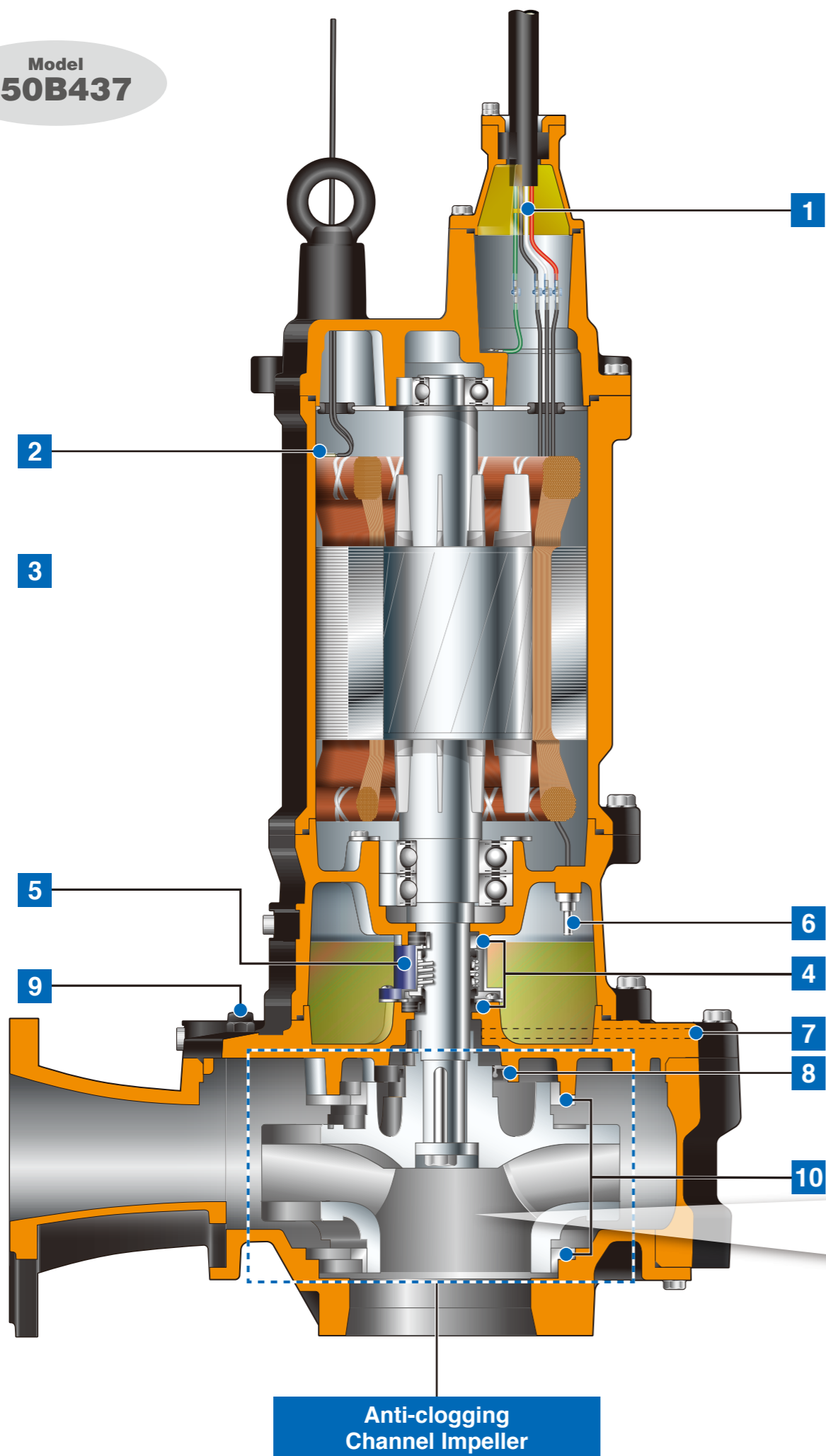

1 Anti-wicking Cable Entry

Prevents water incursion due to capillary action should the cable sheath be damaged or the end of cable submerged. Also prevents moist air from infiltrating the motor housing and condensation from forming inside the housing due to temperature differences between the housing and outside air.

2 Motor Protector

Circle Thermal Protector (7.5kW and below)

Directly cuts the motor circuit if excessive heat builds up or overcurrent occurs in the motor.

Miniature Thermal Protectors (11kW and above)

React to excessive heat caused by dry-running. The bimetal strip opens to cause the control panel to shut the power supply.

3 Water Jacket (150B475 only)

The pump is equipped with a water jacket, around the motor frame. A portion of the pumped liquid is allowed to flow into the water jacket to cool the motor. This design feature permits the unit to operate at low water levels for extended periods of time.

4 Dual Inside Mechanical Seals with Silicon Carbide Faces

Isolated in the oil chamber where a clean, non-corrosive and abrasion-free lubricating environment is maintained. Compared with the water-cooled outside mechanical seal, it reduces the risk of failure caused by dry-heating and adhering matter. The silicon carbide provides 5 times higher corrosion, wear and heat resistance than the tungsten carbide. Rubber parts of the upper and lower fixing rings are made of NBR or FPM (FKM), which provides higher resistance to heat and chemicals.

5 Oil Lifter

Provides lubrication and cooling of the seal faces down to 1/3 of normal oil level, thus maintaining a stable shaft sealing effect and prolonging seal life longer. The Oil Lifter is Tsurumi original design.

6 Leakage Sensor (18.5kW and above, excluding 150B422 and 200B422)

Detects flooding into the oil chamber that may occur in a worst case scenario. When flooding is detected, signals are sent to operate the indicator lamps through the external control panel.

7 Seal Pressure Relief Port (11kW and above of 80 & 100mm bore, 22kW and above of 150mm bore, and 200B422)

Protects the mechanical seal from pump pressure. It also protects the seal face by discharging wear particles.

8 Single/Triple Oil Seals *excluding some models

Labyrinth Ring (150B475 only)

Used as a "Dust Seal", single or triple oil seals protect the mechanical seal from abrasive particles. The labyrinth ring is equipped to provide a better countermeasure against wear caused by high pressure generated in the casing and improve the maintainability.

9 Air Release Valve

Fitted on the water jacket or the pump casing to prevent the air lock. When air flows through the valve, the ball stays at the bottom, but when the pumped water starts to flow, the ball closes the outlet because of its buoyancy.

10 Mouth Ring & Wear Ring (150B437 and 150B475 only)

Prevent wear in the pump casing and suction cover, resulting in reduced maintenance costs.

Anti-clogging Channel Impeller – Pumps solids like liquids –

The impeller employed by B-series pumps is itself configured like a channel to make it less likely for solids and fibrous matter to clog inside the pumps. Depending on the pumping capacity, the pump is outfitted with a semi-open or shrouded impeller, and either 1 or 2 vanes. Equipping your pump with the right impeller minimizes trouble caused by clogged solids.



Semi-open,
Single-channel



Semi-open,
Two-channel



Semi-open,
Two-channel (High Head)



Shrouded,
Two-channel

B -Channel Impeller-

The B-series is a basic heavy-duty, submersible sewage and wastewater pumps providing excellent solids matter passing capability with reliable operation. They offer a wide lineup of discharge bores ranging from 50 - 300 mm and motor outputs of 0.4 - 75 kW, and come in a variety of models including high head type and single-phase BP models that can handle high volume pumping demand. The B-series pumps have accumulated various track record and know-how in a wide range of industrial and water treatment applications for many years.



Discharge Bore: 50 · 80mm

Performance Curves

< 50 · 80mm >

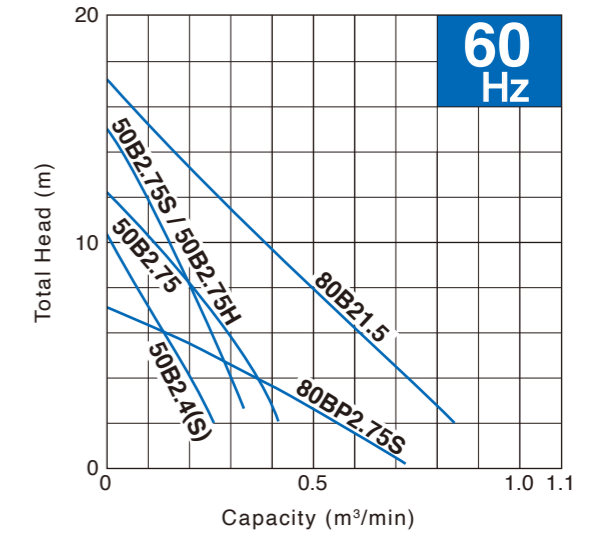
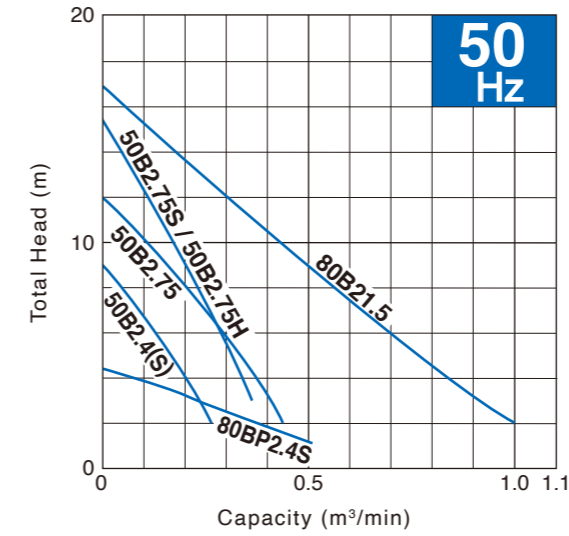

< 80mm -High Head- >

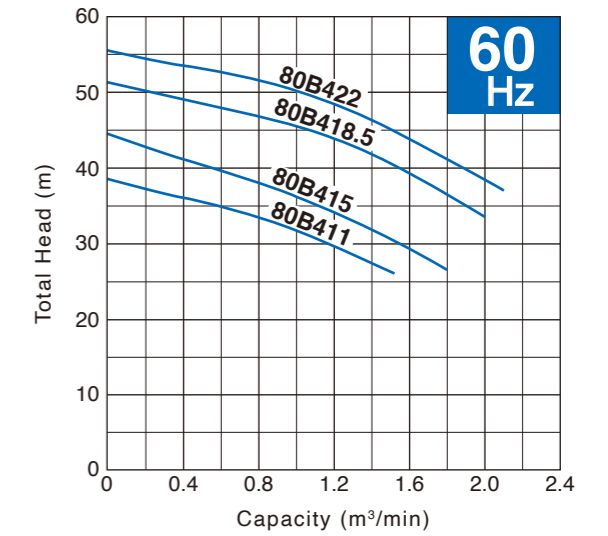
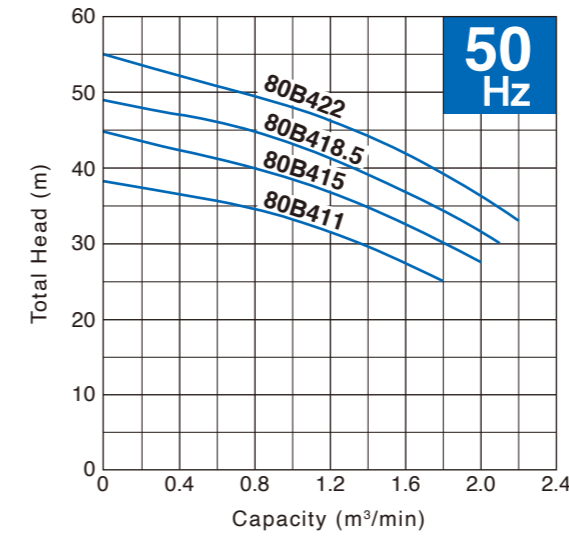

Discharge Bore mm	Model		Motor Output kW	Phase	Starting Method	Dimensions L x W x H 50/60Hz mm		Dry Weight* 50/60Hz kg		Cable Length m
	Free Standing	Guide Rail Fitting				Free Standing	Guide Rail Fitting	Free Standing	Guide Rail Fitting	
50	50B2.4S	TOS50B2.4S	0.4	Single	Capacitor Start	340 x 220 x 453	556 x 220 x 511	25	24	5
	50B2.4	TOS50B2.4	0.4	Three	D.O.L.	340 x 220 x 420	556 x 220 x 478	23	22	6
	50B2.75S	TOS50B2.75S	0.75	Single	Capacitor Start	405 x 250 x 523	621 x 250 x 567	32	30	5
	50B2.75H	TOS50B2.75H	0.75	Three	D.O.L.	405 x 250 x 415	621 x 250 x 458	24	23	6
	50B2.75	TOS50B2.75	0.75	Three	D.O.L.	405 x 250 x 439	621 x 250 x 479	25	24	6
80	80BP2.4S (50Hz)	—	0.4	Single	Capacitor Run	296 x 195 x 363	—	12.7	—	5
	80BP2.75S (60Hz)	—	0.75	Single	Capacitor Run	296 x 195 x 383	—	14.5	—	5
	80B21.5	TOS80B21.5	1.5	Three	D.O.L.	446 x 250 x 536	668 x 250 x 586	36	34	6
80 -High Head-	80B411	TOS80B411	11	Three	Star-Delta	753 x 466 x 1057	926 x 466 x 1021	270/265	265/260	8
	80B415	TOS80B415	15	Three	Star-Delta	791 x 540 x 1057/ 753 x 466 x 1057	942 x 493 x 1021/ 926 x 466 x 1021	290/265	275/265	8
	80B418.5	TOS80B418.5	18.5	Three	Star-Delta	791 x 540 x 1222/ 753 x 466 x 1222	942 x 493 x 1186/ 926 x 466 x 1186	380/360	365/355	10
	80B422	TOS80B422	22	Three	Star-Delta	791 x 540 x 1222	942 x 493 x 1186	385/375	365/360	10

* All weights excluding cable
Weights of guide rail fitting excluding duckfoot bend

Dimensions

Free Standing

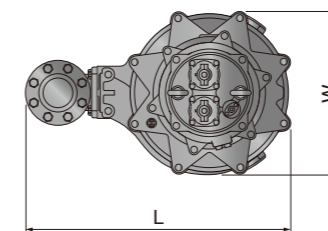

Guide Rail Fitting

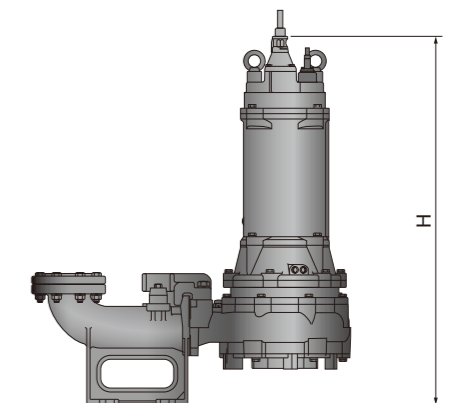
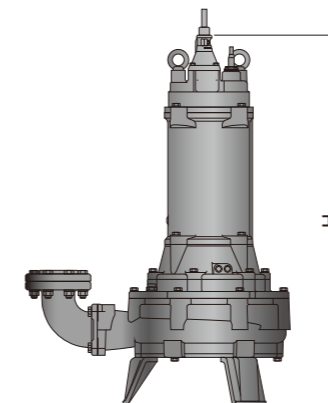
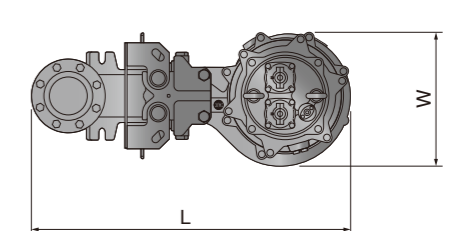

Performance Curves

< 100mm >

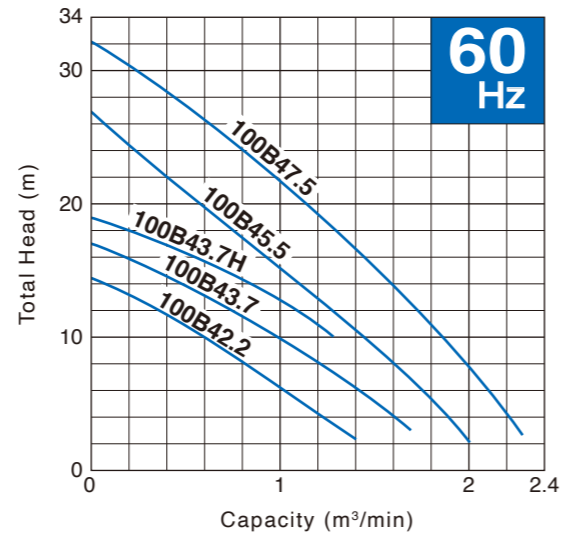
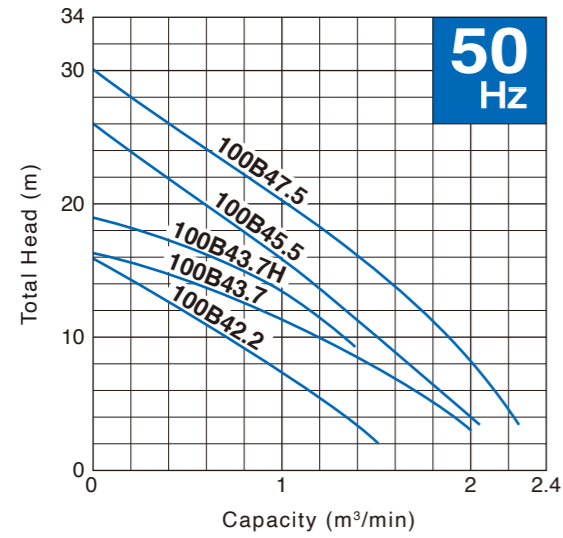

< 100mm -High Head- >

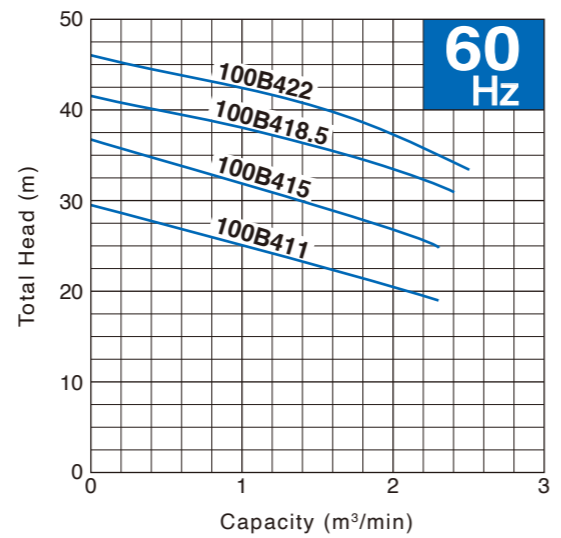
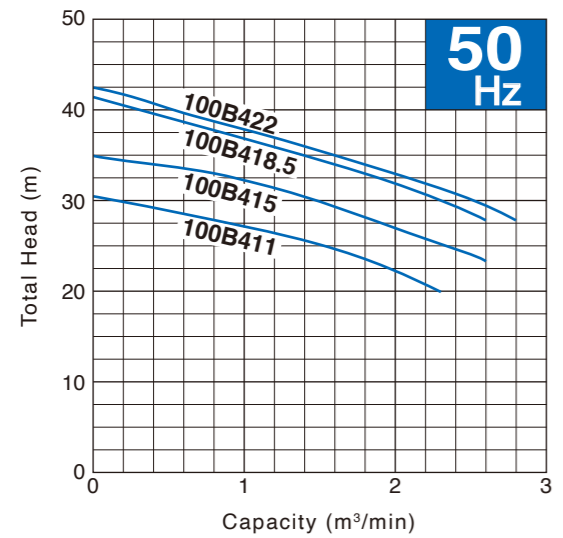

Performance Curves

< 150mm, 3.7 – 22kW >

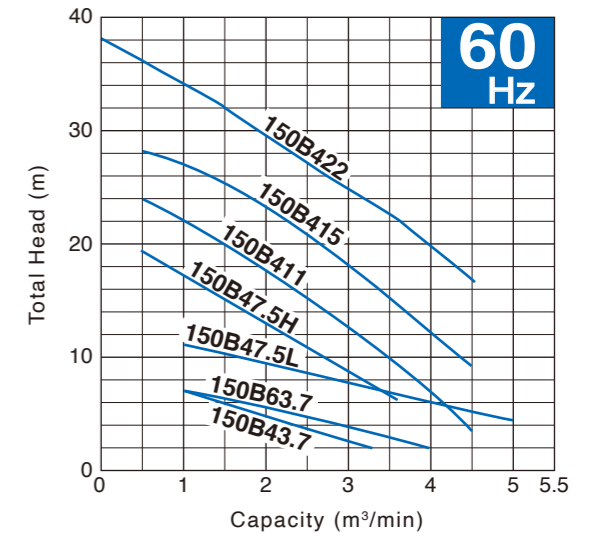
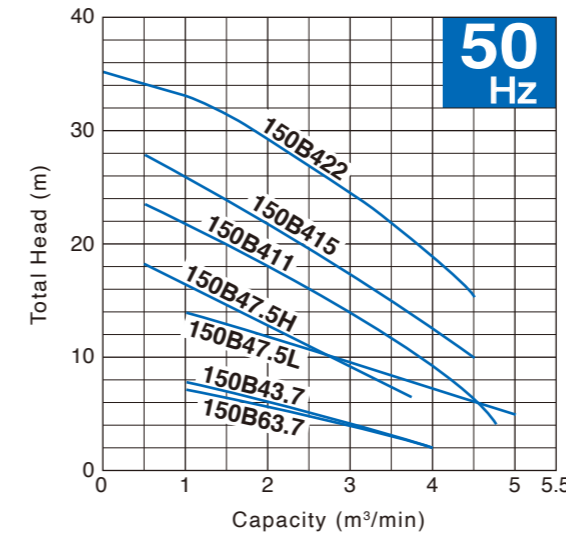

< 150mm, 37 · 75kW >

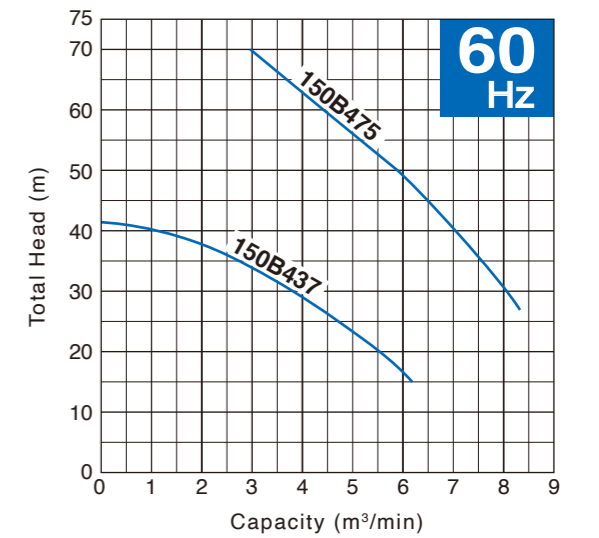
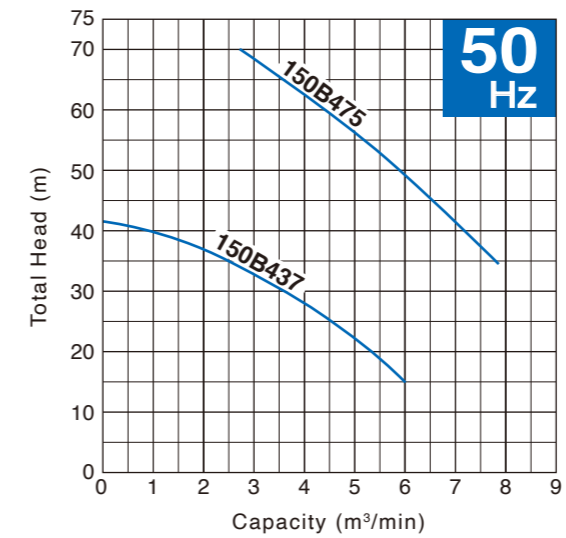

Discharge Bore mm	Model		Motor Output kW	Phase	Starting Method	Dimensions L x W x H*2 50/60Hz mm		Dry Weight*3 50/60Hz kg		Cable Length m
	Free Standing	Guide Rail Fitting				Free Standing	Guide Rail Fitting	Free Standing	Guide Rail Fitting	
100	100B42.2	TOS100B42.2	2.2	Three	D.O.L.	596 x 324 x 642	754 x 324 x 656	66	59	6
	100B43.7	TOS100B43.7	3.7		D.O.L.	601 x 333 x 716	759 x 333 x 725	80	73	6
	100B43.7H	TOS100B43.7H	3.7		D.O.L.	602 x 344 x 692	760 x 344 x 706	82	75	6
	100B45.5	TOS100B45.5	5.5		D.O.L.*1	686 x 410 x 908	905 x 384 x 906	140	133	8
	100B47.5	TOS100B47.5	7.5		D.O.L.*1	686 x 410 x 929	905 x 384 x 927	154	147	8
100 -High Head-	100B411	TOS100B411	11	Three	Star-Delta	775 x 490 x 1114/ 691 x 410 x 1056	994 x 465 x 1091/ 910 x 382 x 1049	280/230	270/220	8
	100B415	TOS100B415	15		Star-Delta	775 x 490 x 1114/ 691 x 410 x 1056	994 x 465 x 1091/ 910 x 382 x 1049	280/230	270/220	8
	100B418.5	TOS100B418.5	18.5		Star-Delta	775 x 490 x 1279	994 x 465 x 1256	370	365/355	10
	100B422	TOS100B422	22		Star-Delta	775 x 490 x 1279	994 x 465 x 1256	370	365/355	10

*1 Star-Delta available upon request
 *2 Refer to page 8 for dimension symbol positions.
 *3 All weights excluding cable
 Weights of guide rail fitting excluding duckfoot bend

Discharge Bore mm	Model		Motor Output kW	Phase	Starting Method	Dimensions L x W x H*2 mm		Dry Weight*3 kg		Cable Length m
	Free Standing	Guide Rail Fitting				Free Standing	Guide Rail Fitting			
150	150B43.7	TOS150B43.7	3.7	Three	D.O.L.	871 x 486 x 875	1065 x 459 x 820	145	120	6
	150B63.7	TOS150B63.7	3.7		D.O.L.*1	838 x 424 x 903	1023 x 395 x 926	188	158	6
	150B47.5H	TOS150B47.5H	7.5		D.O.L.*1	834 x 418 x 951	1028 x 404 x 976	205	175	8
	150B47.5L	TOS150B47.5L	7.5		D.O.L.*1	871 x 486 x 1085	1065 x 459 x 1030	200	175	8
	150B411	TOS150B411	11		Star-Delta	895 x 490 x 1097	1089 x 464 x 1052	245	215	8
	150B415	TOS150B415	15		Star-Delta	895 x 490 x 1167	1089 x 464 x 1122	266	236	8
	150B422	TOS150B422	22		Star-Delta	898 x 492 x 1222	1092 x 470 x 1181	327	298	10
	150B437	TO150B437	37		Star-Delta	1085 x 724 x 1548	1306 x 610 x 1380	640	540	8
	150B475	TO150B475	75		Star-Delta	1305 x 775 x 1896	1517 x 765 x 1786	1180	1140	10

*1 Star-Delta available upon request
 *2 Refer to page 8 for dimension symbol positions.
 *3 All weights excluding cable
 Weights of guide rail fitting excluding duckfoot bend

Performance Curves

< 200 · 250 · 300mm >

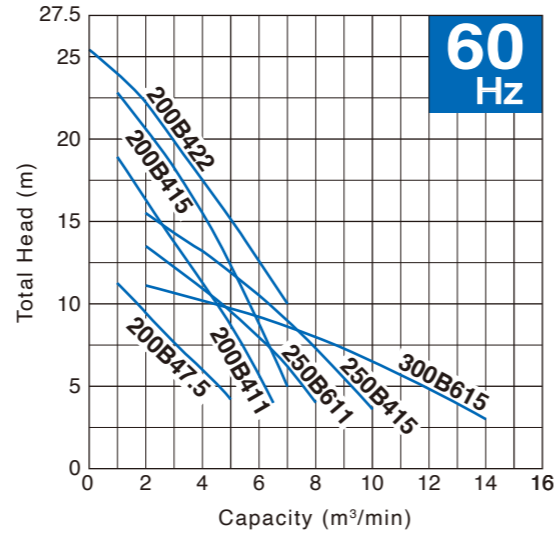
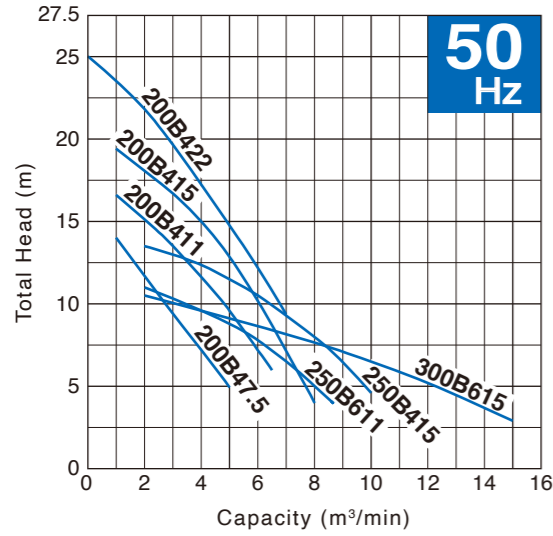

Discharge Bore mm	Model		Motor Output kW	Phase	Starting Method	Dimensions L x W x H*2 mm		Dry Weight*3 kg		Cable Length m
	Free Standing	Guide Rail Fitting				Free Standing	Guide Rail Fitting	Free Standing	Guide Rail Fitting	
200	200B47.5	TO200B47.5	7.5	Three	D.O.L.*1	926 x 486 x 1085	1266 x 459 x 1050	207	212	8
	200B411	TO200B411	11		Star-Delta	926 x 486 x 1131	1266 x 459 x 1096	253	258	8
	200B415	TO200B415	15		Star-Delta	971 x 526 x 1196	1234 x 433 x 1161	291	276	8
	200B422	TOS200B422	22		Star-Delta	953 x 492 x 1222	1117 x 470 x 1181	323	289	10
250	250B611	TO250B611	11	Three	Star-Delta	1203 x 621 x 1211	1513 x 574 x 1165	430	390	8
	250B415	TO250B415	15		Star-Delta	1146 x 558 x 1228	1451 x 497 x 1194	411	371	8
300	300B615	TO300B615	15	Three	Star-Delta	1302 x 656 x 1314	1666 x 652 x 1274	550	520	8

*1 Star-Delta available upon request
 *2 Refer to page 8 for dimension symbol positions.
 *3 All weights excluding cable
 Weights of guide rail fitting excluding duckfoot bend

Submersible pumps with wide solids passages of over 3 inches

BZ-series (80 – 350 mm)

The BZ-series pumps are heavy-duty, submersible sewage and wastewater pumps that are designed with a shrouded single/two-channel impeller and wide passages of over 3 inches (76.2 mm) in diameter to minimize trouble due to clogged solids. This series offers a wide lineup of discharge bores ranging from 80 - 350 mm and motor outputs of 1.5 - 75 kW. For details, refer to the BZ-series catalog [IA101].



Extra-large discharge bores of 350 mm or greater

B-series (350 – 800 mm)

As an option, the B-series pumps can be specially configured with discharge bores of 350 mm and greater, or adapted for dry pit, seawater, high temperature liquids and other special applications. Let Tsurumi know what you need.

Specifications

		B											
		50B2.4S	50B2.4	50B2.75S	50B2.75H 50B2.75	80BP2.4S (50Hz)	80BP2.75S (60Hz)	80B21.5	80B411 80B415	80B418.5 80B422			
PUMP	Discharge Bore mm	50					80						
	Discharge Connection	Threaded Oval Flange*2							Threaded JIS 10kg/cm² Flange				
	Impeller	Semi-open Single-channel					Shrouded Two-channel		Semi-open Single-channel	Semi-open Two-channel			
		Axial Gap											
	Suction Cover	Gray Cast Iron					Glass-fiber Reinforced Resin (PPO-GF)		Gray Cast Iron				
		Ductile Cast Iron		Gray Cast Iron			—		Gray Cast Iron				
	Mouth Ring & Wear Ring	—											
	Oil Seal	Q'ty	Single					—		Single			
			Nitrile Butadiene Rubber					—		Nitrile Butadiene Rubber			
	Labyrinth Ring	—											
	Casing	Gray Cast Iron											
	Shaft Seal	Dual Inside Mechanical Seals (with Oil Lifter)											
		Silicon Carbide											
	MOTOR	Type	Continuous-duty Rated, Dry-type Induction Motor										
Output kW		0.4		0.75		0.4	0.75	1.5	11 15	18.5 22			
Phase		Single	Three	Single	Three	Single		Three					
Pole		2							4				
Speed (S.S.) 50/60Hz min ⁻¹		3000/3600					3000/—	—/3600	3000/3600	1500/1800			
Insulation		E			F or E		E		F				
Starting Method		Capacitor Start	D.O.L.	Capacitor Start	D.O.L.	Capacitor Run		D.O.L.	Star-Delta				
Motor Protector (built-in)		CTP							MTP				
Leakage Sensor (built-in)		—								Electrode			
Lubricant		ml	180		440		240		900	4700	5300		
			Turbine Oil (ISO VG32)					Liquid Paraffin (ISO VG32)		Turbine Oil (ISO VG32)			
Frame		Gray Cast Iron					304 Stainless Steel		Gray Cast Iron				
Outer Cover		—											
Shaft		420 Stainless Steel					304 Stainless Steel		420 Stainless Steel				
Power Cable	m	5	6	5	6	5		6	8	10			
		PVC								Chloroprene Rubber			
Dry Weight*1 50/60Hz	Free Standing kg	25	23	32	24 25	12.7	14.5	36	270/265 290/265	380/360 385/375			
	Guide Rail Fitting kg	24	22	30	23 24	—	—	34	265/260 275/265	365/355 365/360			

*1 All weights excluding cable
 Weights of guide rail fitting excluding duckfoot bend
 *2 Discharge connection for guide rail fitting is a threaded JIS 10kg/cm² flange.

Specifications

		B							B																
		100B42.2	100B43.7	100B43.7H	100B45.5 100B47.5	100B411 150B415	100B418.5 100B422	150B43.7	150B63.7	150B47.5H	150B47.5L	150B411 150B415	150B422	150B437	150B475	200B47.5 200B411	200B415	200B422	250B611	250B415	300B615				
PUMP	Discharge Bore mm	100							150		150					200			250		300				
	Discharge Connection	Threaded JIS 10kg/cm ² Flange							Threaded JIS 10kg/cm ² Flange					JIS 10kg/cm ² Flange											
	Impeller	Semi-open Single-channel	Semi-open Two-channel	Shrouded Two-channel	Semi-open Two-channel		Shrouded Two-channel		Shrouded Two-channel					Shrouded Two-channel											
		Axial Gap		Radial Gap	Axial Gap		Radial Gap		Axial Gap	Radial Gap	Axial Gap		Radial Gap			Axial Gap	Radial Gap	Axial Gap	Radial Gap						
	Suction Cover	Gray Cast Iron							Gray Cast Iron																
	Mouth Ring & Wear Ring	—							—					Gray Cast Iron			—								
	Oil Seal	Q'ty	Single						—		Single			Triple	Single	—		Single	—						
			Nitrile Butadiene Rubber						—		Nitrile Butadiene Rubber								—		Nitrile Butadiene Rubber	—			
	Labyrinth Ring	—							—					304 Stainless Steel			—								
	Casing	Gray Cast Iron							Gray Cast Iron																
Shaft Seal	Dual Inside Mechanical Seals (with Oil Lifter)							Dual Inside Mechanical Seals (with Oil Lifter)																	
	Silicon Carbide							Silicon Carbide																	
MOTOR	Type	Continuous-duty Rated, Dry-type Induction Motor							Continuous-duty Rated, Dry-type Induction Motor																
	Output kW	2.2	3.7		5.5 7.5	11 15	18.5 22	3.7		7.5			11 15	22	37	75	7.5 11	15	22	11	15				
	Phase	Three							Three																
	Pole	4						6		4						6		4		6					
	Speed (S.S.) 50/60Hz min ⁻¹	1500/1800						1000/1200		1500/1800								1000/1200	1500/1800	1000/1200					
	Insulation	F						B		F						B		F		B					
	Starting Method	D.O.L.		D.O.L.* ²		Star-Delta		D.O.L.	D.O.L.* ²	D.O.L.* ²			Star-Delta			D.O.L.* ² Star-Delta		Star-Delta							
	Motor Protector (built-in)	CTP				MTP		CTP		CTP			MTP			CTP MTP		MTP							
	Leakage Sensor (built-in)	—				Electrode		—		—			Electrode			—									
	Lubricant	ml	1350		4200 4800	4700	5300	1350	4200	4200	4800	5400 5700	4600	9500	9400	4800 6500	5500	4600	6000	5500	6000				
			Turbine Oil (ISO VG32)							Turbine Oil (ISO VG32)															
	Frame	Gray Cast Iron							Gray Cast Iron																
	Outer Cover	—							—					Rolled Steel			—								
	Shaft	420 Stainless Steel							420 Stainless Steel																
Power Cable	m	6		8		10	6		8			10	8	10	8		10	8							
		PVC		Chloroprene Rubber			PVC	Chloroprene Rubber	Chloroprene Rubber																
Dry Weight* ¹ 50/60Hz	Free Standing kg	66	80	82	140 154	280/230	370	145	188	205	200	245 266	327	640	1180	207 253	291	323	430	411	550				
	Guide Rail Fitting kg	59	73	75	133 147	270/220	365/355	120	158	175	175	215 236	298	540	1140	212 258	276	289	390	371	520				

*¹ All weights excluding cable
Weights of guide rail fitting excluding duckfoot bend

*² Star-Delta available upon request



We reserve the right to change the specifications and designs without prior notice. The OO series and model OO are indicated with our series/model codes in this catalog.

**TSURUMI
MANUFACTURING CO., LTD.**

Your Dealer